

*Hydraulic diaphragm  
process metering pumps*

**API 675**

**XL**

**XL ▶ A**

**XL ▶ B**

**XL ▶ C**

*The ultimate diaphragm process metering pump!*

# API 675

## Hydraulic diaphragm process metering pumps

### XL - XLA - XLB - XLC

XL pumps series (hydraulic diaphragm positive return) since they were launched on the market achieved a great deal of success thanks to the incredible price/quality ratio. They were further developed and improved with the XLB and XLC pumps. These pumps, with cast iron casing, designed and manufactured in full conformity with API 675 STD and ATEX 94/9/CE, zone of danger 1/21 e 2/22, are suitable for 24/7 demanding industrial applications.

As all hydraulic diaphragm, these pumps come with built-in relief valve, air purge valve and mechanically actuated re-plenishing (smart diaphragm).

This valve guarantees at all times a constant hydraulic balance that overcomes all suction problems (suction valve closing, decreasing of NPSH available).

In case of worsening of the NPSH available, though volumetric efficiency would decrease, pump would still deliver chemical.

In case of complete closing of suction isolating valve, pump would not over-replenish oil and diaphragm would not be over-stretched.

Once operating condition are restored, pump automatically starts delivering with no damage whatsoever.



## Constructional data

- Hydraulic diaphragm pump (single or double), with rupture detector both visual as well as remote (via pressure switch or pressure transmitter for both safe and hazardous areas).
- Design fully conforming with API 675 STD.
- Performances conforming to API 675 STD:
  - ±1% steady state accuracy between 10 and 100% of rated capacity;
  - ± 3% linearity between 10 and 100% of rated capacity;
  - ± 3% repeatability between 10 and 100% of rated capacity.
- Thanks to unique design, pump head can be dismantled and diaphragm checked, with no oil loss.
- Zero flow rate when pressure is zero and adjustment being set to "0%".
- Reduced maintenance; sealess oil-bathed plunger that guarantees as-new volumetric efficiency even after 50000 working hours. Diaphragm, protected by built-in relief valve and mechanical replenisher has working life in excess of 50000 working hours.
- Multiple pumps arrangement on demand (each pump can have different pump size, strokes/1' and wetted materials). These series can be ganged with other positive return pumps (L or X9 series); adjustment can be either independent or common.
- Standard automatic adjustment is via 0,1% steps knob.
- Pumps can be supplied with either electrical or pneumatic actuators (for both safe and hazardous areas) as well as with VSD rated motors.
- Wetted materials are: AISI 316L, PP, PVC and PVDF. On demand exotic materials (alloy 20, Hastelloy C 276, Titanium) can be supplied.
- IEC as standard but NEMA motors can be supplied too.

## Applications field:

- OIL&GAS
- CHEMICAL AND PETRO-CHEMICAL
- POWER GENERATION
- WATER TREATMENT
- PULP & PAPER
- DEMINERALISATION AND RO PLANTS

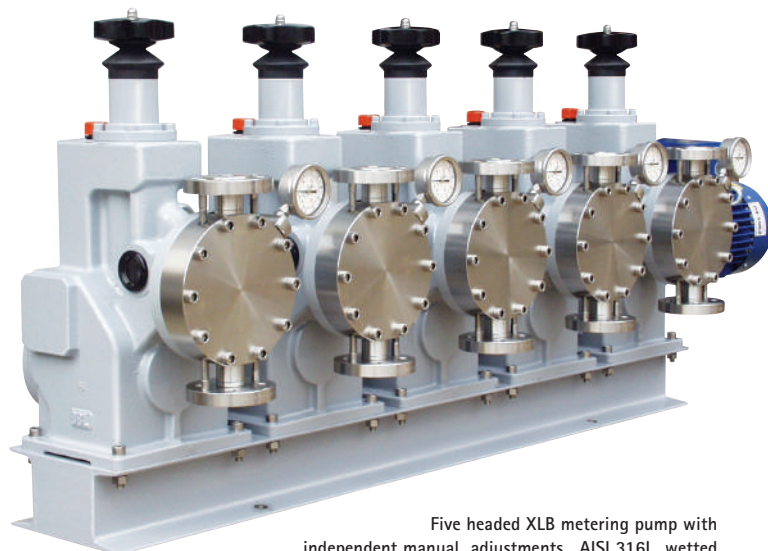

Five headed XLB metering pump with independent manual adjustments. AISI 316L wetted parts pump head with double diaphragm and visual rupture detector. Pump conforms to ATEX 94/9/CE, suitable, thanks to the double hydraulic diaphragm system, for dosing of flammable, toxic and explosive chemicals.



XLB double hydraulic diaphragm metering pump with PVDF wetted parts. Diaphragm rupture detector via ATEX II 2 G Ex-d IIC T6. pressure switch. Because of the pH of the dosed chemical pressure switch had to be protected by a PTFE diaphragm fitted into two in Hastelloy C 276<sup>®</sup> backing rings. Because of the weight of the pressure switch and its protection system they are both supported by a bar made of AISI 316 bar. Same material is used for the base-plate to comply with stringent project specifications. >



XL pump with single diaphragm and PVDF wetted parts. Automatic adjustment of the flow rate electrical actuator that being IP66 and thanks to the anticondensation heater, turns out to be suitable for installation in harsh environments such as saline and/or desertic areas with high humidity and wide temperature variation.

Automatic adjustments

## Control systems

### Z type electrical actuator >

**XL/XLB/XLC** can be equipped with Z type electrical actuator, with following characteristics:

- IP 66 STD
- Manual emergency override
- Anticondensation heater (on demand)
- Non standard voltages and frequencies
- External automatic/manual selector

Flow rate is adjusted according to following input signals:

- 4-20 mA, 0-20 A, 20-4 mA e 0-10 V
- Pulses (0÷2 Hz - 0÷30 Hz)
- RS 485 protocol
- PROFIBUS DP - VØ



### Electrical actuator >

- ATEX II 2GD EEx-d IIB T4 IP6X
- 115/230V - 1 - 50/60 Hz
- 230/400V - 3 - 50/60 Hz
- 4-20 mA signal and feedback
- Manual emergency override
- Anticondensation heater (on demand)



### W type pneumatic actuator >

- ATEX II 2G c IIC T6
- Pneumatic actuator type WA.
- Air instrument 3÷15 PSI
- Air supply 4-6 bar
- Emergency manual override



### Knob >

- Micrometer control reading 0-100%.
- 0,1% steps sealed magnifying lens indicator.



Manual adjustment

# XL

<b>Pump:</b>	• Single and multiple up to 6 heads
<b>Max flow rate:</b>	• 480 L/h
<b>Max pressure:</b>	• 15 bar
<b>Motors:</b>	• Threephase 0,37 kW - 0,75 kW - 1,5 kW 230/400 V - 50/60Hz - 4 poles IP55 - CLF - IEC38
<b>Stroke:</b>	• 15/25mm
<b>Materials:</b>	• Cast iron pump body
<b>Weighth:</b>	• 60÷70 Kgs

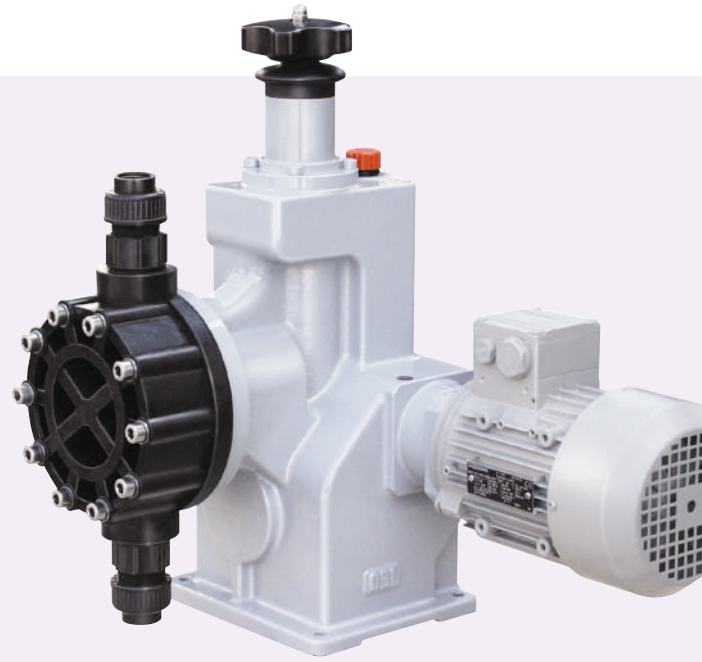

480 l/h 15 bar

# API 675

XL pump technically advanced hydraulic diaphragm positive return pump, low cost, due to reduced number of components; can be used in both process and service applications.

- Hydraulic diaphragm metering pump both single and double
- Threaded (BSP female) or flanged connections (both DIN or ANSI)
- Fully conforming with API 675 STD
- Fully conforming with ATEX 94/9/CE, 1/21 and 2/22 zone of danger. Suitable for flammable chemicals thanks to the double diaphragm system
- PP wetted parts (single diaphragm only), AISI 316L, PVC e PVDF (with single and double diaphragm design)
- With PP, AISI 316L and PVDF wetted parts up to 60 °C pumping temperature
- With PVC wetted parts up to 40 °C pumping temperature

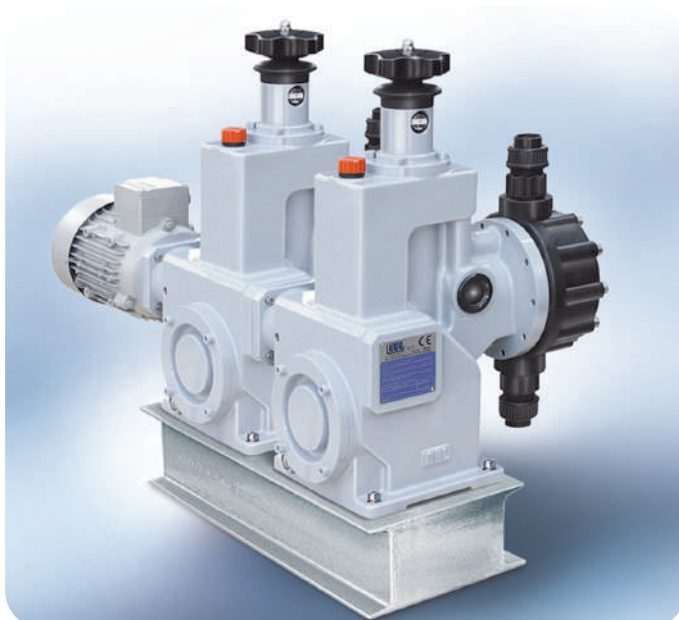

< Two-headed XL.  
Each pump can have different number of strokes/1' and different wetted materials.

< XL single hydraulic diaphragm pump head with injection moulded glass filled PP and threaded connections. Max pressure up to 15 bar g.

## Technical characteristics

TYPE	STROKES/1'	MAX FLOW RATE l/H	PVS SET PRESS. bar g			CONNECTIONS		
			WORK PRES.	PVS	kW	THREADED	FLANGED	
							UNI	ANSI
<b>50 Hz</b>								
<b>PP-PP11-PP32</b>								
XL 15.50	40	63	12	15	0,37	1/2" BSPF	DN15-PN16	1/2" 150
XL 25.50	40	105	12	15	0,37	1/2" BSPF	DN15-PN16	1/2" 150
XL 25.50	60	155	12	15	0,37	1/2" BSPF	DN20-PN16	3/4" 150
XL 25.50	82	215	12	15	0,75	1/2" BSPF	DN20-PN16	3/4" 150
XL 25.50	100	260	12	15	0,75	3/4" BSPF	DN20-PN16	3/4" 150
XL 25.50	123	320	12	15	0,75	3/4" BSPF	DN20-PN16	3/4" 150
XL 25.50	140	370	11	14	0,75	1" BSPF	DN25-PN16	1" 150
XL 25.50	160	430	10	13	0,75	1" BSPF	DN25-PN16	1" 150
XL 25.50	185	480	8	10	0,75	1" BSPF	DN25-PN16	1" 150
<b>MA-MMA</b>								
XL 15.50	40	63	12	15	0,37	1/2" BSPF	DN15-PN16	1/2" 150
XL 25.50	40	105	12	15	0,37	1/2" BSPF	DN15-PN16	1/2" 150
XL 25.50	60	155	12	15	0,37	1/2" BSPF	DN20-PN16	3/4" 150
XL 25.50	82	215	12	15	0,75	1/2" BSPF	DN20-PN16	3/4" 150
XL 25.50	100	260	12	15	0,75	3/4" BSPF	DN20-PN16	3/4" 150
XL 25.50	123	320	12	15	0,75	3/4" BSPF	DN20-PN16	3/4" 150
XL 25.50	140	370	11	14	0,75	1" BSPF	DN25-PN16	1" 150
XL 25.50	160	430	10	13	0,75	1" BSPF	DN25-PN16	1" 150
XL 25.50	185	480	8	10	0,75	1" BSPF	DN25-PN16	1" 150
<b>MP-MMP/MS-MMS</b>								
XL 15.50	40	63	12	15	0,37	-	DN15-PN16	1/2" 150
XL 25.50	40	105	12	15	0,37	-	DN15-PN16	1/2" 150
XL 25.50	60	155	12	15	0,37	-	DN20-PN16	3/4" 150
XL 25.50	82	215	12	15	0,75	-	DN20-PN16	3/4" 150
XL 25.50	100	260	12	15	0,75	-	DN25-PN16	1" 150
XL 25.50	123	320	12	15	0,75	-	DN25-PN16	1" 150
XL 25.50	140	370	11	14	0,75	-	DN25-PN16	1" 150
XL 25.50	160	430	10	13	0,75	-	DN25-PN16	1" 150
XL 25.50	185	480	8	10	0,75	-	DN25-PN16	1" 150
<b>60 Hz</b>								
<b>PP-PP11-PP32</b>								
XL 15.50	48	76	12	15	0,37	1/2" BSPF	DN15-PN16	1/2" 150
XL 25.50	48	126	12	15	0,37	1/2" BSPF	DN15-PN16	1/2" 150
XL 25.50	72	186	12	15	0,75	1/2" BSPF	DN20-PN16	3/4" 150
XL 25.50	96	258	12	15	0,75	3/4" BSPF	DN20-PN16	3/4" 150
XL 25.50	121	312	12	15	0,75	3/4" BSPF	DN20-PN16	3/4" 150
XL 25.50	144	384	11	14	0,75	1" BSPF	DN25-PN16	1" 150
XL 25.50	168	444	10	13	0,75	1" BSPF	DN25-PN16	1" 150
<b>MA-MMA</b>								
XL 15.50	48	76	12	15	0,37	1/2" BSPF	DN15-PN16	1/2" 150
XL 25.50	48	126	12	15	0,37	1/2" BSPF	DN15-PN16	1/2" 150
XL 25.50	72	186	12	15	0,75	1/2" BSPF	DN20-PN16	3/4" 150
XL 25.50	96	258	12	15	0,75	3/4" BSPF	DN20-PN16	3/4" 150
XL 25.50	121	312	12	15	0,75	3/4" BSPF	DN20-PN16	3/4" 150
XL 25.50	144	384	11	14	0,75	1" BSPF	DN25-PN16	1" 150
XL 25.50	168	444	10	13	0,75	1" BSPF	DN25-PN16	1" 150
<b>MP-MMP/MS-MMS</b>								
XL 15.50	48	76	12	15	0,37	-	DN15-PN16	1/2" 150
XL 25.50	48	126	12	15	0,37	-	DN15-PN16	1/2" 150
XL 25.50	72	186	12	15	0,75	-	DN20-PN16	3/4" 150
XL 25.50	96	258	12	15	0,75	-	DN25-PN16	1" 150
XL 25.50	121	312	12	15	0,75	-	DN25-PN16	1" 150
XL 25.50	144	384	11	14	0,75	-	DN25-PN16	1" 150
XL 25.50	168	444	10	13	0,75	-	DN25-PN16	1" 150

< XL pump with single diaphragm and moulded glass fibre reinforced PP wetted parts. Automatic adjustment of the flow rate electrical (IP66 as STD). The robustness of the PP wetted parts allows dosing of any chemicals where AISI 316L would be unsuitable, at a working pressure up to 12 bar g. With the same pump head, combining metallic seats and balls (AISI 316L, incoloy 825, Hastelloy C 276 ®), it is possible to offer premium quality/price versions for dosing problematic chemicals such as 50% caustic, viscous polymers and concentrated sulphuric acid.

### OVERALL DIMENSIONS

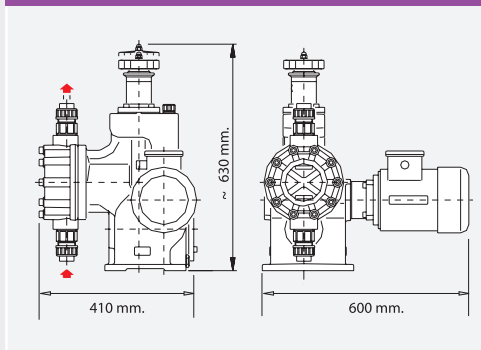

### MATERIALS OF CONSTRUCTION

PARTS	PP	PP11	PP32	MA MMA	MP MMP	MS MMS
LIQUID END	PP	PP	PP	AISI 316L	PVC	PVDF
DIAPHRAGM	PTFE	PTFE	PTFE	PTFE	PTFE	PTFE
VALVE SEAT	PVC	AISI 316L	INCOLOY 825	AISI 316L	PVC	PVDF
VALVE GUIDE	PP	PP	PP	AISI 316L	PP	PVDF
VALVE	PIREX	AISI 316L	HASTELLOY C 276	AISI 316L	PIREX	PIREX
VALVE HOUSING	PP	PP	PP	AISI 316L	PVC	PVDF
VALVE SEAL	FPM	FPM	FPM	FPM	FPM	FPM
FLANGE	PVC	PVC	PVC	AISI 316L	PVC	PVDF

### MODEL NUMBER

#### KEY TO SYMBOL

PUMP TYPE	ø PLUNGER
PP	PP EXECUTION
PP11	PP+AISI-316L VALVE & VALVE SEAT Z
4±20	mA ELECTRIC ACTUATOR W 0,2-1
BAR	PNEUMATIC ACTUATOR ... THREADED
CONNECTIONS	
F	UNI-DIN FLANGED CONNECTIONS
FA	ANSI FLANGED CONNECTIONS
N*	STROKES PER MINUTE
	STROKE mm.

XL 25 50 PP 120 F Z

# XLA

<b>Pump:</b>	• Single and multiple up to 14 heads
<b>Max flow rate:</b>	• 20 L/h
<b>Max pressure:</b>	• 200 bar
<b>Motors:</b>	• Threephase 0,37 kW (size 71-B14) 0,75 kW (size 80-B14) 50/60Hz-230/480 V Unel Mec STD-4 poles-IP55-CLF-IEC34-1
<b>Stroke:</b>	• 6 mm
<b>Materials:</b>	• Cast iron casing
<b>Weight:</b>	• 35 Kgs



20 l/h 200 bar

## API 675

XLA pump is a low flow-high pressure hydraulically balanced diaphragm metering pump. Like the XL series includes a dependable stroke adjustment mechanism that generates true mechanical full motion performance over a 10:1 turndown. The API675 compliant design includes double diaphragm leak detection as standard.

### *Diaphragm metering pumps deliver more than you expect*

- **PRECISION FLOW CONTROL**

The rugged full motion variable eccentric offers 0-100% adjustment with a +/- 1% accuracy over a 10:1 turndown. An advanced hydraulic management system assures consistent performance and rapid recovery from system upsets.

- **CHEMICAL DUTY**

The double PTFE leak detection diaphragm and component check ceramic seats and ruby balls offers outstanding chemical durability for your most demanding applications.

- **LONG LIFE**

Full casting iron/steel drive end with rolling element bearing and bronze worm gearing ensures the long life and worry free operation. Oil bath lubrication with level sight glass makes preventative maintenance checks easy.

- **STANDARDS**

Designed and tested to API675 standards. Fully CE and ATEX compliant. Close coupled motor frames of 71-B14 Unel Mec (and 56C Nema available). Small footprint and modular multiplexing provide predictable footprint requirements.

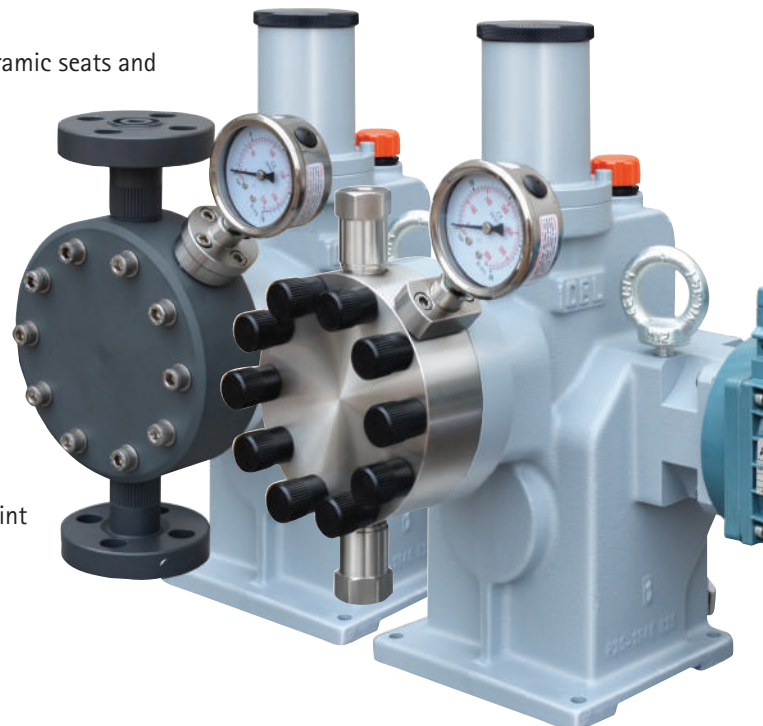

## Technical characteristics

< XLA single hydraulic diaphragm pump head flanged connections.



PUMP	STROKES PER MIN.	MAX FLOW RATE L/H								NPSH-R	MAX PRESSURE BAR		CONNECTIONS			
		MIN FLOW RATE L/H									WORK	PSV	THREADED		FLANGED	
		WORKING PRESSURE BAR											A	UNI	ANSI	
		200	175	150	130	100	80	60	40		20	10				
<b>50Hz</b>																
XLA.12	100	1,25	1,6	1,8	2,1	2,35	2,55	2,8	3	3,2	10	210	250	1/4"NPT f	DN15	1/2"ANSI
XLA.12	118	0,2	0,2	0,2	0,2	0,2	0,2	0,3	0,3	0,3	10	210	250	1/4"NPT f	DN15	1/2"ANSI
XLA.12	145	1,55	1,9	2,2	2,5	2,8	3,1	3,35	3,65	3,9	10	210	250	1/4"NPT f	DN15	1/2"ANSI
XLA.12	182	0,2	0,2	0,2	0,3	0,3	0,3	0,3	0,4	0,4	10	210	250	1/4"NPT f	DN15	1/2"ANSI
XLA.15	25	2	2,3	2,7	3,1	3,4	3,7	4	4,3	4,6	10	210	250	1/4"NPT f	DN15	1/2"ANSI
XLA.15	36	0,2	0,25	0,3	0,3	0,3	0,4	0,4	0,4	0,45	10	210	250	1/4"NPT f	DN15	1/2"ANSI
XLA.15	50	2,5	3	3,4	3,8	4,2	4,9	5,3	5,7	6,1	10	210	250	1/4"NPT f	DN15	1/2"ANSI
XLA.15	70	0,25	0,3	0,3	0,4	0,4	0,5	0,5	0,6	0,6	10	210	250	1/4"NPT f	DN15	1/2"ANSI
XLA.15	100	-	-	-	1,1	1,15	1,15	1,2	1,25	1,3	10	130	155	1/4"NPT f	DN15	1/2"ANSI
XLA.15	118	-	-	-	0,15	0,15	0,15	0,15	0,15	0,15	10	130	155	1/4"NPT f	DN15	1/2"ANSI
XLA.15	145	-	-	-	1,6	1,65	1,7	1,75	1,8	1,85	10	130	155	1/4"NPT f	DN15	1/2"ANSI
XLA.15	182	-	-	-	0,2	0,2	0,2	0,2	0,2	0,2	10	130	155	1/4"NPT f	DN15	1/2"ANSI
XLA.18	118	-	-	-	2,2	2,3	2,35	2,4	2,5	2,55	10	130	155	1/4"NPT f	DN15	1/2"ANSI
XLA.18	145	-	-	-	0,3	0,3	0,3	0,3	0,3	0,3	10	130	155	1/4"NPT f	DN15	1/2"ANSI
XLA.20	118	-	-	-	3,1	3,2	3,3	3,4	3,5	3,6	10	130	155	1/4"NPT f	DN15	1/2"ANSI
XLA.20	145	-	-	-	0,35	0,35	0,35	0,35	0,35	0,35	10	130	155	1/4"NPT f	DN15	1/2"ANSI
XLA.25	100	-	-	-	4,2	4,4	4,5	4,6	4,8	4,85	10	130	155	1/4"NPT f	DN15	1/2"ANSI
XLA.25	118	-	-	-	0,4	0,4	0,4	0,4	0,4	0,4	10	130	155	1/4"NPT f	DN15	1/2"ANSI
XLA.25	145	-	-	-	5,1	5,2	5,4	5,6	5,8	5,9	10	130	155	1/4"NPT f	DN15	1/2"ANSI
XLA.25	182	-	-	-	0,5	0,5	0,5	0,5	0,5	0,5	10	130	155	1/4"NPT f	DN15	1/2"ANSI
XLA.25	225	-	-	-	6,5	6,6	6,8	7	7,3	7,4	10	130	155	1/4"NPT f	DN15	1/2"ANSI
XLA.25	250	-	-	-	0,6	0,6	0,7	0,8	0,8	0,9	10	130	155	1/4"NPT f	DN15	1/2"ANSI
XLA.25	275	-	-	-	8,1	8,3	8,5	8,8	9,2	9,3	10	130	155	1/4"NPT f	DN15	1/2"ANSI
XLA.25	300	-	-	-	0,7	0,8	0,8	0,9	1	1	10	130	155	1/4"NPT f	DN15	1/2"ANSI
XLA.25	325	-	-	-	8,2	8,5	8,8	9,1	9,2	9,3	10	100	120	1/4"NPT f	DN15	1/2"ANSI
XLA.25	350	-	-	-	0,7	0,7	0,7	0,7	0,7	0,7	10	100	120	1/4"NPT f	DN15	1/2"ANSI
XLA.25	375	-	-	-	10,3	10,7	11,9	11,5	11,6	11,7	10	100	120	1/4"NPT f	DN15	1/2"ANSI
XLA.25	400	-	-	-	1	1	1	1,2	1,2	1,2	10	100	120	1/4"NPT f	DN15	1/2"ANSI
XLA.25	425	-	-	-	-	-	-	-	-	-	9,5	80	96	1/4"NPT f	DN15	1/2"ANSI
XLA.25	450	-	-	-	-	-	-	-	-	-	9,5	80	96	1/4"NPT f	DN15	1/2"ANSI
XLA.25	475	-	-	-	-	-	-	-	-	-	9	*50	60	1/4"NPT f	DN15	1/2"ANSI
XLA.25	500	-	-	-	-	-	-	-	-	-	9	*50	60	1/4"NPT f	DN15	1/2"ANSI
XLA.25	525	-	-	-	-	-	-	-	-	-	9	*50	60	1/4"NPT f	DN15	1/2"ANSI
XLA.25	550	-	-	-	-	-	-	-	-	-	9	*50	60	1/4"NPT f	DN15	1/2"ANSI
XLA.25	575	-	-	-	-	-	-	-	-	-	9	*50	60	1/4"NPT f	DN15	1/2"ANSI
XLA.25	600	-	-	-	-	-	-	-	-	-	9	*50	60	1/4"NPT f	DN15	1/2"ANSI
XLA.25	625	-	-	-	-	-	-	-	-	-	9	*50	60	1/4"NPT f	DN15	1/2"ANSI
XLA.25	650	-	-	-	-	-	-	-	-	-	9	*50	60	1/4"NPT f	DN15	1/2"ANSI
XLA.25	675	-	-	-	-	-	-	-	-	-	9	*50	60	1/4"NPT f	DN15	1/2"ANSI
XLA.25	700	-	-	-	-	-	-	-	-	-	9	*50	60	1/4"NPT f	DN15	1/2"ANSI
XLA.25	725	-	-	-	-	-	-	-	-	-	9	*50	60	1/4"NPT f	DN15	1/2"ANSI
XLA.25	750	-	-	-	-	-	-	-	-	-	9	*50	60	1/4"NPT f	DN15	1/2"ANSI
XLA.25	775	-	-	-	-	-	-	-	-	-	9	*50	60	1/4"NPT f	DN15	1/2"ANSI
XLA.25	800	-	-	-	-	-	-	-	-	-	9	*50	60	1/4"NPT f	DN15	1/2"ANSI
XLA.25	825	-	-	-	-	-	-	-	-	-	9	*50	60	1/4"NPT f	DN15	1/2"ANSI
XLA.25	850	-	-	-	-	-	-	-	-	-	9	*50	60	1/4"NPT f	DN15	1/2"ANSI
XLA.25	875	-	-	-	-	-	-	-	-	-	9	*50	60	1/4"NPT f	DN15	1/2"ANSI
XLA.25	900	-	-	-	-	-	-	-	-	-	9	*50	60	1/4"NPT f	DN15	1/2"ANSI
XLA.25	925	-	-	-	-	-	-	-	-	-	9	*50	60	1/4"NPT f	DN15	1/2"ANSI
XLA.25	950	-	-	-	-	-	-	-	-	-	9	*50	60	1/4"NPT f	DN15	1/2"ANSI
XLA.25	975	-	-	-	-	-	-	-	-	-	9	*50	60	1/4"NPT f	DN15	1/2"ANSI
XLA.25	1000	-	-	-	-	-	-	-	-	-	9	*50	60	1/4"NPT f	DN15	1/2"ANSI
XLA.25	1025	-	-	-	-	-	-	-	-	-	9	*50	60	1/4"NPT f	DN15	1/2"ANSI
XLA.25	1050	-	-	-	-	-	-	-	-	-	9	*50	60	1/4"NPT f	DN15	1/2"ANSI
XLA.25	1075	-	-	-	-	-	-	-	-	-	9	*50	60	1/4"NPT f	DN15	1/2"ANSI
XLA.25	1100	-	-	-	-	-	-	-	-	-	9	*50	60	1/4"NPT f	DN15	1/2"ANSI
XLA.25	1125	-	-	-	-	-	-	-	-	-	9	*50	60	1/4"NPT f	DN15	1/2"ANSI
XLA.25	1150	-	-	-	-	-	-	-	-	-	9	*50	60	1/4"NPT f	DN15	1/2"ANSI
XLA.25	1175	-	-	-	-	-	-	-	-	-	9	*50	60	1/4"NPT f	DN15	1/2"ANSI
XLA.25	1200	-	-	-	-	-	-	-	-	-	9	*50	60	1/4"NPT f	DN15	1/2"ANSI
XLA.25	1225	-	-	-	-	-	-	-	-	-	9	*50	60	1/4"NPT f	DN15	1/2"ANSI
XLA.25	1250	-	-	-	-	-	-	-	-	-	9	*50	60	1/4"NPT f	DN15	1/2"ANSI
XLA.25	1275	-	-	-	-	-	-	-	-	-	9	*50	60	1/4"NPT f	DN15	1/2"ANSI
XLA.25	1300	-	-	-	-	-	-	-	-	-	9	*50	60	1/4"NPT f	DN15	1/2"ANSI
XLA.25	1325	-	-	-	-	-	-	-	-	-	9	*50	60	1/4"NPT f	DN15	1/2"ANSI
XLA.25	1350	-	-	-	-	-	-	-	-	-	9	*50	60	1/4"NPT f	DN15	1/2"ANSI
XLA.25	1375	-	-	-	-	-	-	-	-	-	9	*50	60	1/4"NPT f	DN15	1/2"ANSI
XLA.25	1400	-	-	-	-	-	-	-	-	-	9	*50	60	1/4"NPT f	DN15	1/2"ANSI
XLA.25	1425	-	-	-	-	-	-	-	-	-	9	*50	60	1/4"NPT f	DN15	1/2"ANSI
XLA.25	1450	-	-	-	-	-	-	-	-	-	9	*50	60	1/4"NPT f	DN15	1/2"ANSI
XLA.25	1475	-	-	-	-	-	-	-	-	-	9	*50	60	1/4"NPT f	DN15	1/2"ANSI
XLA.25	1500	-	-	-	-	-	-	-	-	-	9	*50	60	1/4"NPT f	DN15	1/2"ANSI
XLA.25	1525	-	-	-	-	-	-	-	-	-	9	*50	60	1/4"NPT f	DN15	1/2"ANSI
XLA.25	1550	-	-	-	-	-	-	-	-	-	9	*50	60	1/4"NPT f	DN15	1/2"ANSI
XLA.25	1575	-	-	-	-	-	-	-	-	-	9	*50	60	1/4"NPT f	DN15	1/2"ANSI
XLA.25	1600	-	-	-	-	-	-	-	-	-	9	*50	60	1/4"NPT f	DN15	1/2"ANSI
XLA.25	1625	-	-	-	-	-	-	-	-	-	9	*50	60	1/4"NPT f	DN15	1/2"ANSI
XLA.25	1650	-	-	-	-	-	-	-	-	-	9	*50	60	1/4"NPT f	DN15	1/2"ANSI
XLA.25	1675	-	-	-	-	-	-	-	-	-	9	*50	60	1/4"NPT f	DN15	1/2"ANSI
XLA.25	1700	-	-	-	-	-	-	-	-	-	9	*50	60	1/4"NPT f	DN15	1/2"ANSI
XLA.25	1725	-	-	-	-	-	-	-	-	-	9	*50	60	1/4"NPT f	DN15	1/2"ANSI
XLA.25	1750	-	-	-	-	-	-	-	-	-	9	*50	60	1/4"NPT f	DN15	1/2"ANSI
XLA.25																

# XLB

**Pump:** • Single and multiple up to 6 heads

**Max flow rate:** • 430 L/h

**Max pressure:** • 40 bar

**Motors:** • Threephase 0,75 kW - 1,5 kW  
230/400 V - 50/60Hz - 4 poles  
IP55 - CLF - IEC38

**Stroke :** • 15/25mm

**Materials :** • Cast iron pump body

**Weigth :** • 60÷70 Kgs

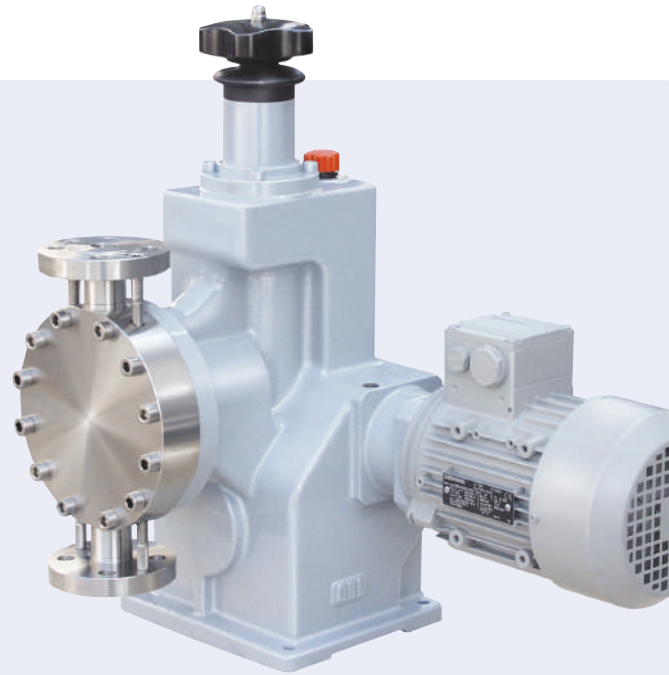

430 l/h 40 bar

## API 675

XLB hydraulic diaphragm positive return pump, suitable for industrial process applications; heavy duty mechanism for operating pressures up to 35 bar, suitable for 24h/7 duties.

- Hydraulic diaphragm metering pump both single and double
- Threaded (BSP female) or flanged connections (both DIN or ANSI)
- Fully conforming with API 675 STD
- Fully conforming with ATEX 94/9/CE, 1/21 and 2/22 zone of danger. Suitable for flammable chemicals thanks to the double diaphragm system
- AISI 316L, PVC e PVDF wetted parts (with single and double diaphragm design)
- With AISI 316L and PVDF wetted parts up to 60 °C pumping temperature
- With PVC wetted parts up to 40 °C pumping temperature

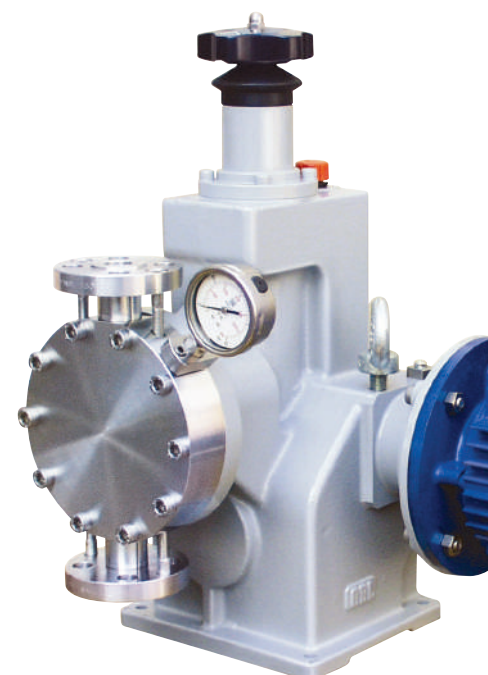
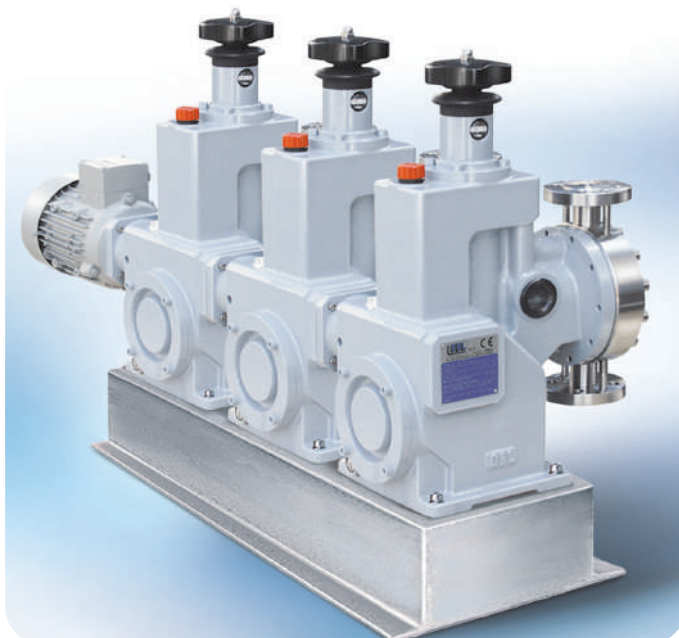

< Three-headed XLB pump with AISI 316L wetted parts.

< XLB single hydraulic diaphragm pump head with AISI 316L wetted parts and ANSI # 300 RF flanged connections.

Max pressure up to 30 bar g.

## Technical characteristics

TYPE	STROKES/1'	MAX FLOW RATE I/H	PVS SET PRESS. bar g						CONNECTIONS		
			0,37 kW		0,75 kW		1,5 kW		THREADED	FLANGED	
			W.PRES	PSV	W.PRES	PSV	W.PRES	PSV		UNI	ANSI
<b>50 Hz</b>											
<b>MA - MMA</b>											
XLB 15.50	40	63	12	15	35	40	-	-	1 1/2" BSPF	DN15-PN40	1/2" 300
XLB 25.50	40	105	12	15	35	40	-	-	1 1/2" BSPF	DN15-PN40	1/2" 300
XLB 25.50	60	155	12	15	25	30	-	-	1 1/2" BSPF	DN20-PN40	3/4" 300
XLB 25.50	82	215	8	10	16	20	25	30	1 1/2" BSPF	DN20-PN40	3/4" 300
XLB 25.50	100	260	-	-	15	18	25	30	3/4" BSPF	DN20-PN40	3/4" 300
XLB 25.50	123	320	-	-	12	15	25	30	3/4" BSPF	DN20-PN40	3/4" 300
XLB 25.50	140	370	-	-	11	14	20	25	1" BSPF	DN25-PN40	1" 300
XLB 25.50	160	430	-	-	10	13	16	20	1" BSPF	DN25-PN40	1" 300
<b>MS - MMS</b>											
XLB 15.50	40	63	12	15	15	18,5	-	-	-	DN15-PN25	1/2" 150
XLB 25.50	40	105	12	15	15	18,8	-	-	-	DN15-PN25	1/2" 150
XLB 25.50	60	155	12	15	15	18,5	-	-	-	DN20-PN25	3/4" 150
XLB 25.50	82	215	8	10	15	18,5	-	-	-	DN20-PN25	3/4" 150
XLB 25.50	100	260	-	-	15	18,5	-	-	-	DN25-PN25	1" 300
XLB 25.50	123	320	-	-	12	15	15	18,5	-	DN25-PN25	1" 300
XLB 25.50	140	370	-	-	11	14	15	18,5	-	DN25-PN25	1" 300
XLB 25.50	160	430	-	-	10	13	15	18,5	-	DN25-PN25	1" 300
<b>60 Hz</b>											
<b>MA - MMA</b>											
XLB 15.50	48	76	12	15	35	40	-	-	1 1/2" BSPF	DN15-PN40	1/2" 300
XLB 25.50	48	126	12	15	35	40	-	-	1 1/2" BSPF	DN15-PN40	1/2" 300
XLB 25.50	72	186	12	15	18	22	25	30	1 1/2" BSPF	DN20-PN40	3/4" 300
XLB 25.50	96	258	-	-	15	18	25	30	3/4" BSPF	DN20-PN40	3/4" 300
XLB 25.50	121	312	-	-	12	15	25	30	3/4" BSPF	DN20-PN40	3/4" 300
XLB 25.50	144	384	-	-	11	14	20	25	1" BSPF	DN25-PN40	1" 300
XLB 25.50	168	444	-	-	10	12	16	20	1" BSPF	DN25-PN40	1" 300
<b>MS - MMS</b>											
XLB 15.50	48	76	12	15	15	18,5	-	-	-	DN15-PN25	1/2" 150
XLB 25.50	48	126	12	15	15	18,5	-	-	-	DN15-PN25	1/2" 150
XLB 25.50	72	186	12	15	15	18,5	-	-	-	DN20-PN25	3/4" 150
XLB 25.50	96	258	-	-	15	18,5	-	-	-	DN25-PN25	1" 150
XLB 25.50	121	312	-	-	12	15	15	18,5	-	DN25-PN25	1" 150
XLB 25.50	144	384	-	-	11	14	15	18,5	-	DN25-PN25	1" 150
XLB 25.50	168	444	-	-	10	12	15	18,5	-	DN25-PN25	1" 150

< XLB metering pump with ANSI # 300 RF flanged connections (max pressure up to 30 bar g), double hydraulic diaphragm, AISI 316L wetted parts and visual rupture detector via pressure gauge. Pump fully conforms to ATEX 94/9/CE and API STD 675.



### OVERALL DIMENSIONS

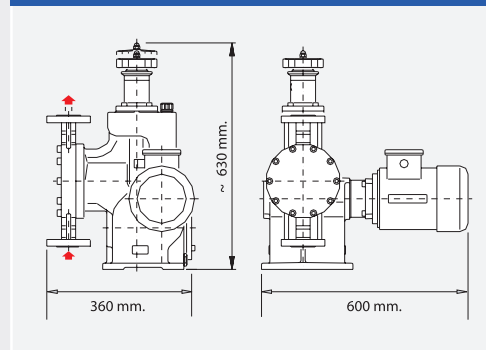

### MATERIALS OF CONSTRUCTION

PARTS	MA/MMA	MS/MMS
LIQUID END	AISI 316L	PVDF
DIAPHRAGM	PTFE	PTFE
VALVE SEAT	AISI 316L	PVDF
VALVE GUIDE	AISI 316L	PVDF
VALVE	AISI 316L	PIREX
VALVE HOUSING	AISI 316L	PVDF
VALVE SEAL	FPM	FPM
FLANGE	AISI 316L	PVDF

### MODEL NUMBER

#### KEY TO SYMBOL

PUMP TYPE	Ø PLUNGER
MA	AISI 316L EXECUTION
MS	PVDF EXECUTION
Z 4÷20	mA ELECTRIC ACTUATOR W 0,2-1 BAR PNEUMATIC ACTUATOR ... THREADED
CONNECTIONS	
F	UNI-DIN FLANGED CONNECTIONS
FA	ANSI FLANGED CONNECTIONS
N°	STROKES PER MINUTE
	STROKE mm.

XLB 25 50 MA 120 FA Z

**Pump:** • Single and multiple up to 6 heads

**Max flow rate:** • 1500 L/h

**Max pressure:** • 20 bar

**Motors:** • Trifase 0,75 kW - 1,5 kW - 2,2 kW  
230/400 V - 50/60Hz - 4 poli  
IP55 - CLF - IEC38

**Stroke :** • 44,5 mm

**Materials:** • Cast iron pump body

**Weigth :** • 170 Kgs



1500 l/h 20 bar

# API 675

XLC pumps have high STD basic version: flanged connections and double diaphragm with local visual rupture detection via pressure gauge, suitable for dangerous toxic, flammable and even explosive chemicals. XLC pumps are suitable for 24/7 industrial applications.

- Double hydraulic diaphragm metering pumps
- Flanged connections only (either DIN or ANSI)
- Fully conforming with API 675 STD
- Fully conforming with ATEX 94/9/CE, 1/21 and 2/22 zone of danger. Suitable for flammable chemicals thanks to the double diaphragm system
- AISI 316L, PVC e PVDF wetted parts
- With AISI 316L and PVDF wetted parts up to 75 °C pumping temperature
- With PVC wetted parts up to 40 °C pumping temperature



< XLC PVC basic version with: double diaphragm with local visual rupture detector and flanged connections.

## Technical characteristics

< XLC pump with double hydraulic diaphragm, rupture detector via both pressure gauge and pressure switch (local/remote).

AISI 316L/PTFE wetted materials only and threaded connection to DIN 11851.

TYPE	STROKES/1'	MAX FLOW RATE l/H	MAX PRESSURE - PVS SET PRESS. bar g			FLANGED CONNECTIONS	
			0,75 kW	1,5 kW	2,2 kW	UNI	ANSI
<b>50 Hz</b>							
<b>AISI 316L</b>							
XLC A	40	350	14	20	20	DN 25	1" 300RF
XLC A	60	550	10	20	20	DN 25	1" 300RF
XLC A	82	750	8	17	20	DN 40	1 1/2" 300RF
XLC A	100	920	6	12	17	DN 40	1 1/2" 150RF
XLC A	123	1150	-	10	15	DN 40	1 1/2" 150RF
XLC A	140	1300	-	8	12	DN 40	1 1/2" 150RF
XLC A	160	1500	-	6	12	DN 40	1 1/2" 150RF
<b>PVC</b>							
XLC P	40	350	12	12	-	DN 25	1" 150RF
XLC P	60	550	10	12	-	DN 25	1" 150RF
XLC P	82	750	8	12	-	DN 40	2" 150RF
XLC P	100	920	6	12	12	DN 40	2" 150RF
XLC P	123	1150	-	10	12	DN 40	2" 150RF
XLC P	140	1300	-	8	12	DN 40	2" 150RF
XLC P	160	1500	-	6	12	DN 40	2" 150RF
<b>PVDF</b>							
XLC S	40	350	14	18,5	-	DN 25	1" 150RF
XLC S	60	550	10	18,5	-	DN 25	1" 150RF
XLC S	82	750	8	17	18,5	DN 40	2" 150RF
XLC S	100	920	6	12	17	DN 40	2" 150RF
XLC S	123	1150	-	10	15	DN 40	2" 150RF
XLC S	140	1300	-	8	12	DN 40	2" 150RF
XLC S	160	1500	-	6	12	DN 40	2" 150RF
<b>60 Hz</b>							
<b>AISI 316L</b>							
XLC A	48	420	13	20	20	DN 25	1" 300RF
XLC A	72	660	10	17	20	DN 25	1" 300RF
XLC A	96	900	6	12	17	DN 40	1 1/2" 300RF
XLC A	121	1150	-	10	15	DN 40	1 1/2" 150RF
XLC A	144	1300	-	8	12	DN 40	1 1/2" 150RF
XLC A	165	1540	-	6	12	DN 40	1 1/2" 150RF
<b>PVC</b>							
XLC P	48	420	12	12	-	DN 25	1" 150RF
XLC P	72	660	10	12	-	DN 25	1" 150RF
XLC P	96	900	6	12	12	DN 40	2" 150RF
XLC P	121	1150	-	10	12	DN 40	2" 150RF
XLC P	144	1300	-	8	12	DN 40	2" 150RF
XLC P	165	1540	-	6	12	DN 40	2" 150RF
<b>PVDF</b>							
XLC S	48	420	12	18,5	-	DN 25	1" 150RF
XLC S	72	660	10	18,5	-	DN 25	1" 150RF
XLC S	96	900	6	12	17	DN 40	2" 150RF
XLC S	121	1150	-	10	15	DN 40	2" 150RF
XLC S	144	1300	-	8	12	DN 40	2" 150RF
XLC S	165	1540	-	6	12	DN 40	2" 150RF

< XLC AISI 316L basic version with: double diaphragm with local visual rupture detector and flanged connections.

### OVERALL DIMENSIONS

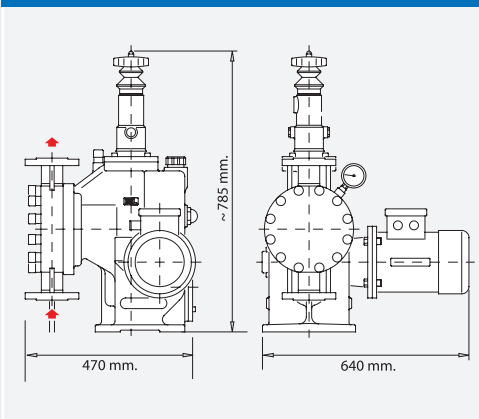

### MATERIALS OF CONSTRUCTION

PARTS	A	P	S
LIQUID END	AISI 316L	PVC	PVDF
DIAPHRAGM	PTFE	PTFE	PTFE
VALVE SEAT	AISI 316L	PVC	PVDF
VALVE GUIDE	AISI 316L	PP	PVDF
VALVE	AISI 316L	PIREX	PIREX
VALVE HOUSING	AISI 316L	PVC	PVDF
VALVE SEAL	FPM	FPM	FPM
FLANGE	AISI 316L	PVC	PVDF

### MODEL NUMBER

#### KEY TO SYMBOL

PUMP TYPE	
A	AISI 316L EXECUTION
P	PVC EXECUTION
S	PVDF EXECUTION
4	4÷20 mA ELECTRIC ACTUATOR W 0,2-1
BAR	PNEUMATIC ACTUATOR ... UNI/DIN
FLANGED CONNECTIONS FA	ANSI FLANGED CONNECTIONS MEMBRANE RUPTURE DETECTOR
N°	STROKES PER MINUTE

